

CromPack[®]

vacuum packaging machines



VM 52 TANDDEM SERIES

Crompack VM Series products, the use of advanced graphic display and a choice of 4 different languages has been made very easy. The principle of respect for nature set out Crompack products, food products using appropriate codex. Crompack brand products are CE certified and RoHS standards are made.



VM SERIES vacuum packaging machines

TECHNICAL DATA



DIMENSIONS

Machines Dimensios	mm	1550*895*803 h
Chamber Size	mm	(720*540*220)*220 h
Pump	mc/h	105 m3
Sealing Bar	mm	520*4 mm
Power	Voltage	380 volt-50/60 Hz
Kw / h	Kw	1,1 (1,5)
Weight	Kg	208
Closing Operation	Sec	18-25

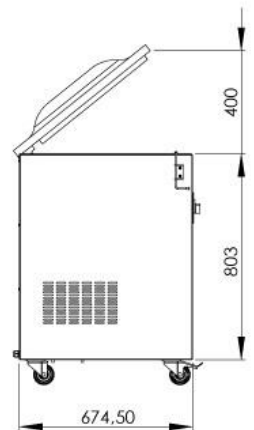
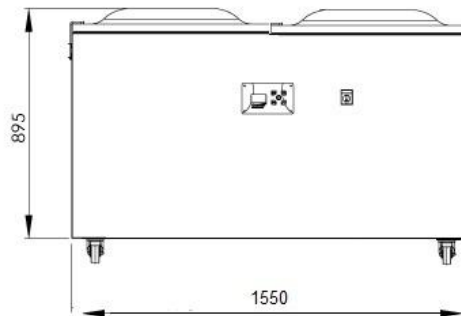
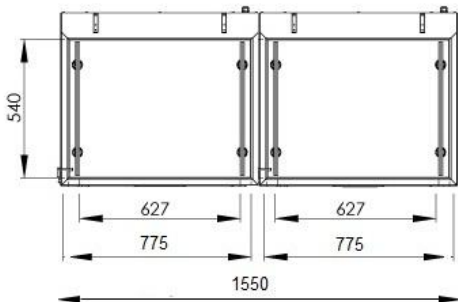

SEALING JAW

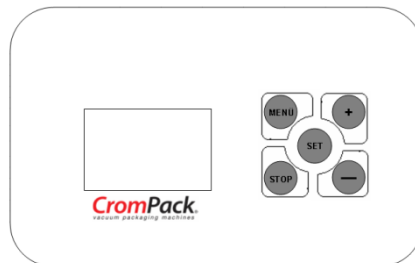

LCD PANEL

